

**[Item: .....]**

**EZ Lane SL1000 Swing Glass Optical Turnstile**

Electric motor driven swinging glass gate (speed gate) for barrier-free access for access control in office, industry and administration buildings

**Function:**

- Comfortable contact free usage
- Complete opening of swing door for a convenient passage
- Quick opening times (0.6s – 1 s depending on wing size and material)
- Early open functionality
- Open gate option
- Automatic closing after set time span
- 2-way operation in entry and exit direction
- Integrated pulse counter with separate counting for both directions
- Error history for technical service
- Indoor and outdoor installation

**Design:**

- Design housing with flowing lines, slender silhouette and tender forms
- Frame illumination and floor illumination (option)
- No visible connection elements
- Stylish color design in basalt (sides) and anthracite (frame)
- Optional: customer-specific colors

**Safety & security:**

- Sensitive impact detection for passenger safety (< 400N according to EN12453)
- Low energy drive system with max. 1.69J, static opening and closing force max. 67N (according to EN 16005)
- Secure position or free rotation in case of alarm signal
- Free rotation in both directions in the case of power outage
- Automatic return to closed position upon power return or reset of alarm signal
- Gate transmits warning notification in case of forced entry
- Random generator for the control of persons and bags
- No under-crawling
- No over-climbing through different barrier height options of up to 1800 mm
- Controlled internal gate area for additional passenger safety
- Prevention of tailgating or backpacking
- Detection of passage direction and alarm in case of wrong passage direction

**Control and drive system:**

- Integrated control system with display for parameterization and set-up
- Integrated drive system for minimum 10 million opening and closing cycles (MCBF)
- Connection for 100 – 240 VAC, 50/60 Hz
- Connections for all current card reader systems
- 8 digital inputs with free allocable functions
- 4 digital outputs and 6 output relays for illumination control and status readout (free allocable)
- USB and LAN connection for firmware update and remote access
- Integrated web server

**Control and drive system:**

- Integrated drive system for minimum 10 million opening and closing cycles (MCBF)
- Integrated control system with display for parameterization and set-up
- Functions and parameters can be activated and parameterized as well as switched via I/O connections: passage direction, hold-open time, passage direction indication, illumination options, behaviour in case of alarm, notification in case of forced entry
- Connection for 100 – 240 VAC, 50/60 Hz

- Connections for all current card reader systems
- 8 digital inputs with free allocable functions
- 4 digital outputs and 6 output relays for illumination control and status readout (freely allocable)
- 3 connector slots for extension modules
- USB and LAN connection for firmware update and remote access
- Integrated web server

**Materials:**

- Housing: 2 component-polyurethane material
- Highly resistant to impacts, scratches and abrasion
- Resistant against corrosion, UV light, detergents and disinfectants
- Environmentally friendly disposal as household garbage
- Enclosure protection rating: IP54
- Blocking element: single-layer safety glass or acrylic glass

**Dimensions:**

- Housing dimensions: 1300 mm x 1050 mm x 180 mm (L x H x D)
- Passage width: 600 mm (Standard) / 900 mm (wide lane) / Specials on request
- Barrier height: 889 mm (Standard) / 1800 mm (full-height version) / Specials on request
- Total width for standard passage width: 960 mm
- Installation space for card reader in card reader post: 60 x 80 x 40 mm (W x H x D)

**Installation:**

- Screw mounting on stable floor surface
- Alternative mounting on unfinished floor by use of adjustable foundation frame (see accessories)
- Alternative glue mounting by use of a metal base plate (see accessories)

Temperature range: -20 to + 131°F

Weight: approx. 89 lbs. per cabinet

Installation execution by manufacturer trained installation specialist, including user training and hand-over of inspection manual, declaration of conformity according to EC machinery directive/ low voltage directive, EMC directive.

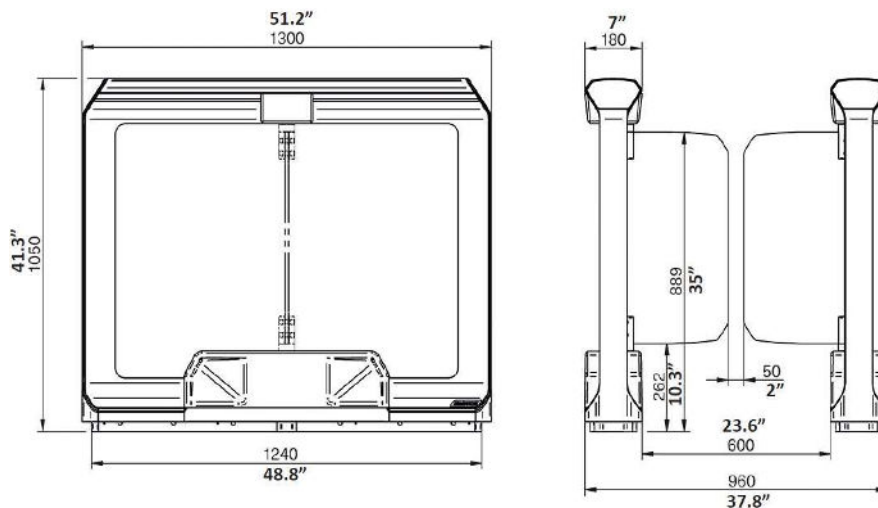

**SL1000 Optical Turnstile Standard Dimensions (single lane)**