

**Expert Advice. Great Value. Contact Us Today!**

**Call:** 203-647-9147 **Email:** sales@haywardts.com

**Website:** www.haywardts.com

## HT80 Standard Passage

- Full Height for Maximum Security
- Aluminum Profile Frame Design
- Exterior Clear Sidewalls
- Stylish Oval Anodized Arms



**HT80 Standard Passage**

### **Applications:**

The HT80 turnstile provides full height security with an aluminum profile frame. It's unique design combines oval arms with clear exterior sidewalls and is a lower cost alternative to stainless steel models. The heavy gauge frame and arms have an anodized finish that is strong, durable and long lasting. It is frequently used in factories and corrosive environments when aesthetics and frame materials are important considerations.

### **About Hayward Turnstiles:**

Hayward Turnstiles has over 50 years of expertise in quality manufacturing of precision aircraft parts and reliable turnstiles.

Our factory, in Milford, CT, is AS9100 Certified to aerospace standards resulting in superior turnstiles. Engineered to industrial grade specifications, they are durable and built tough for long lasting performance. Proudly made in the USA, we distribute worldwide with installations across the globe.

Get in touch with us for expert advice, design assistance, project review, free quotes and for help with your security needs.

## HT80 Specifications

### Applications:

The HT80 turnstile provides full height security with an aluminum profile frame. It is frequently used in factories and corrosive environments when aesthetics and frame materials are important considerations.

### Product Finish:

Clear anodized. Other finishes upon request.

### Design & Construction:

- Designed for secure operations with visual appeal
- Anodized aluminum frame with clear lifetime finish
- Aluminum ovaline arms
- High impact durable Lexan glazing (yoke)
- Stainless fasteners
- Hardened tool steel locking bars, cams and roller assemblies
- Permanently lubricated sealed bearings

### Turnstile Operation:

- Choice of right or left-handed direction
- Self-centering mechanism with hydraulic shock suppression

- Fail-Safe (free passage on power failure)
- Fail-Lock (locked passage on power failure)
- Easily integrates to access control and fire safety systems
- Interfaces with card readers, biometrics, wireless remotes and push buttons.

### Options:

- Card reader mounting plates
- Electronic resettable counter with LCD display and 7-year lithium battery
- Red/Green indicator lights
- Low voltage canopy lighting
- Tailgate detection
- Additional options upon request.

### Electrical Specifications:

Power supply input 100-240VAC (.7 amp) 50/60hz output 24VDC (1.3 – .55 amp) UL Approved

### Warranty:

Units are warranted against defects in materials and workmanship for one year.



## HT80 Dimensions

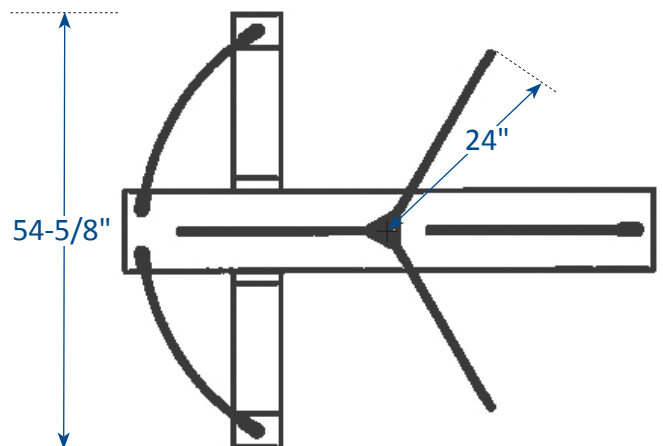
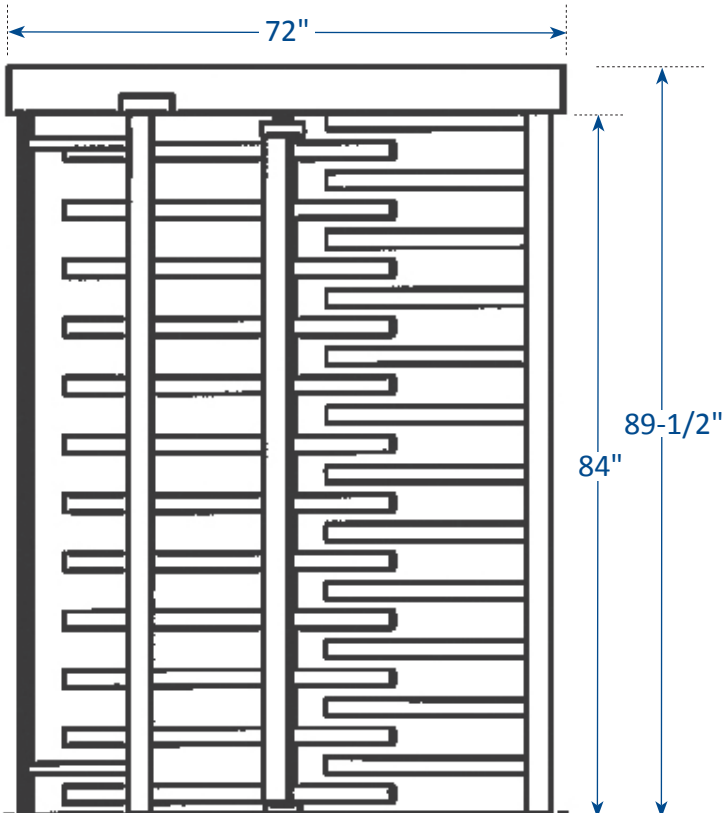

**Expert Advice. Great Value. Contact Us Today!**

Call: 203-647-9147 Email: sales@haywardts.com

Website: www.haywardts.com

**HAYWARD TURNSTILES, INC.**  
160 Wampus Lane, Milford CT 06460